

## Minimizing EMI : System Design Guidelines

*Tech Support Document* 2/10

Unitronics products are designed to operate in a typical industrial environment. This document gives guidelines on how to design your system for optimal performance in noisy environments.

After installation, check your system periodically, in particular after installing new machinery close to the system.

Devices Emitting high EMF .....	1
Wiring Separation .....	2
Enclosing and Earthing .....	2
I/O Wiring: General Guidelines.....	2
Signal (Communication, I/O) Line Filtering.....	3
Wiring Power Supplies for I/O Expansion Modules .....	4
Power-line filtering .....	5
Connecting the EX-A1 communication cable: .....	7

### **Devices Emitting high EMF**

High voltage, high current, and high frequency circuits such as high voltage / high current power supplies, high power converters and amplifiers, contactors and solenoids, motors and motor-drives may cause severe electro-magnetic disturbances that may affect the operation of other nearby computerized devices such as PLCs or I/O modules.

**Those high voltage, high current, and high frequency circuits should not share the same cabinet with PLCs or I/O modules.**

If this is unavoidable, within the cabinet, either:

- Physically separate these sources from PLCs and I/O modules with large metal earthed plates. Such a plate should be large enough to partition the cabinet into two cubicles.
- Separate these sources and their cabling from PLCs and I/O modules as described in the section Wiring Separation.

## **Wiring Separation**

Use separate wiring ducts for each of the following groups:

- Digital inputs, digital outputs, 24VDC (power supply for the PLC and I/O Expansion Modules), communications, analog inputs, and analog outputs.
- Lines that are connected to the power grid, 230/115, 24VAC, all AC lines such as motor driver outputs, noisy DC lines such as DC servo drives and motors.  
Separate these groups by at least 10cm (4"). If this is not possible, cross the ducts at a 90° angle.

## **Enclosing and Earthing**

- It is recommended to install the PLC and I/O modules in a closed metallic cabinet. This will significantly improve interference immunity.
- Make sure that the cabinet and cabinet door are properly earthed. Please refer to the cabinet manufacturer instructions for proper installation and earthing.
- When you earth devices, minimize wire impedance by using a wire that is as short and thick as possible, 3.3mm<sup>2</sup> (12 AWG), up to 10cm long recommended. Connect the line to nearest possible grounding point in the cabinet, preferably a grounding plate or the cabinet body. Be sure to remove any paint or other non-conductive coating between the wire terminal and metal as this may cause poor conduction.

## **I/O Wiring: General Guidelines**

- Route each I/O signal / signal-group along with a dedicated common wire (e.g. 0V). This serves as a signal return path and increases interference immunity.  
Connect common wires at the respective common pins of the module where the specified I/O port is located. Please refer to the module installation guide for details.
- For all types of analog and high-speed I/Os:
- Use shielded twisted pair cable
- Do not use the shield as a signal or as a return conductor
- Ground the shield at the closest grounding point-to the I/O port, preferably a grounding plate or the cabinet body.  
This connection method usually gives the best interference immunity. However, in some cases, grounding the shield at both ends of the cable is preferable. In this case, be sure that both points have the same potential in order to eliminate ground currents through the shield.

- Route those signals separately from high voltage / high current and AC wiring, as explained in the section Wiring Separation.

## **Signal (Communication, I/O) Line Filtering**

Some environments may induce greater EMI than the typical industrial environment. Extra power and/or signal line filtering may improve the system's immunity to EMI.

If signal-line filtering is required, please use the following guidelines in addition to the guidelines provided by the filter manufacturer:

- Place the filter as close as possible to the target device(s); maximum wire length is 10 cm.
- Signal lines can be filtered using rounded ferrite cores. To maximize their effect, wind the wire through the ferrite core multiple times to attenuate high frequencies as shown below.
- Always pass both the signal and signal return wires thru the ferrite core.

If multiple I/O lines share the same common return wire, pass all of these I/O lines and their return wire through the same ferrite core.



***Multiple Windings to Maximize Filtration***

## Wiring Power Supplies for I/O Expansion Modules

The examples below are based on the EX-A1.

- If the power-supply is closer to the PLC than it is to the module's power supply (EX-A1):
  - Create 0V and 24V junctions at the PLC respective terminals (see the following figure) and directly connect the PLC main supply lines to the EX-A1.
  - Continue daisy-chaining the supply lines to the expansion I/O units.**Please ensure that the wire segment which carries the 0V between the EX-A1 and the PLC does not branch.**

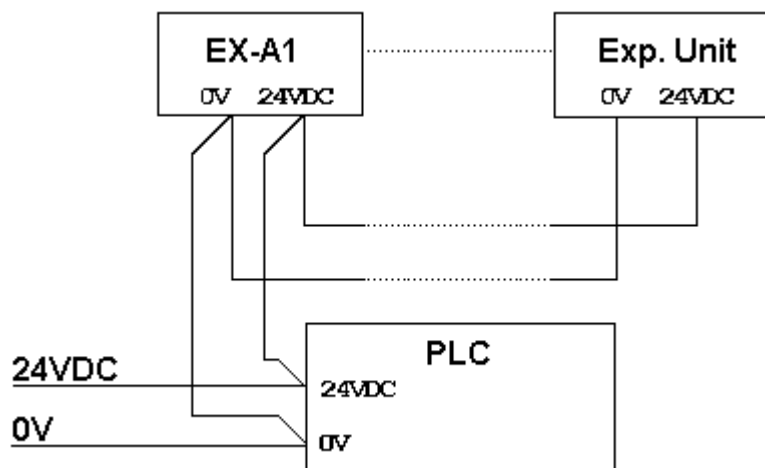

### *PLC Connected First (when power-supply is near the PLC)*

- If the power-supply is closer to the EX-A1 than it is to the PLC:
  - Create 0V and 24V junctions at the EX-A1 respective terminals (see the following figure) and directly connect the EX-A1 main supply lines to the PLC.
  - Split the supply lines at the EX-A1 terminals and continue daisy-chaining them to the expansion I/O units.**Please ensure that the wire segment which carries the 0V between the EX-A1 and the PLC does not branch.**

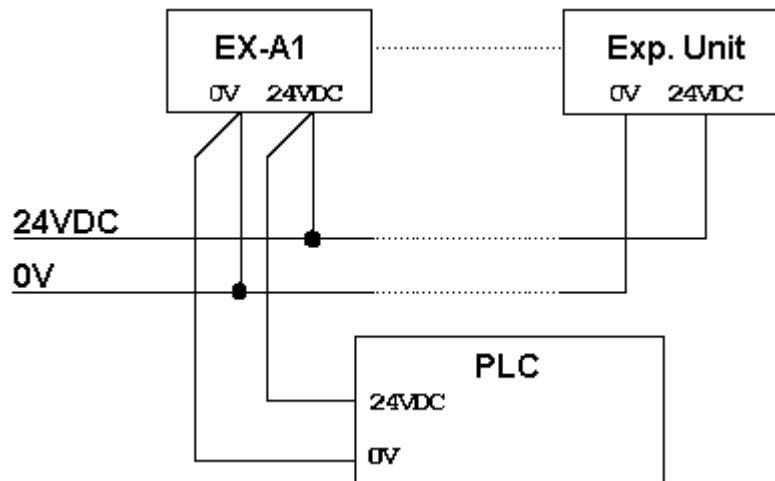

***EX-A1 Connected First (when power supply is near the EX-A1)***

## **Power-line Filtering**

Some environments may induce greater EMI than the typical industrial environment. Extra power and/or signal line filtering may improve the system's immunity to EMI.

If power-line filtering is required, please use the following guidelines in addition to the guidelines provided by the filter manufacturer:

- Use of power-line filters that comprise an earthing terminal is recommended. Ground the filter earth terminal as explained in the section Enclosing and Earthing.
  - Place the filter as close as possible to the target device(s). The maximum wire length is 10 cm.
  - When using the EX-A1 expansion adapter:
  - Place one filter for both the PLC and the EX-A1 as instructed below. **Please note** that you must use a single line filter for both the PLC and EX-A1.
  - If the power-supply is closer to the PLC than it is to the EX-A1:
    - Install and connect the power-line filter as close as possible to the PLC. The maximum wire length is 10 cm. Please refer to the filter manufacturer documentation for installation information.
    - Create 0V and 24V junctions at the PLC respective terminals (see the following figure) and directly connect the PLC main supply lines to the EX-A1.
    - Continue daisy-chaining the supply lines to the expansion I/O units.
- Please ensure that the wire segment which carries the 0V between the EX-A1 and the PLC does not branch.**

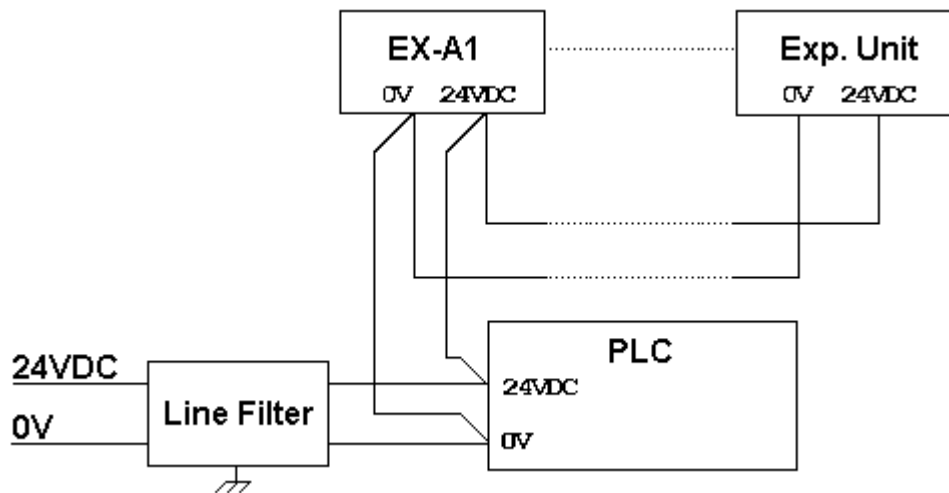

***PLC Connected First (when power-supply is near the PLC)***

- If the power-supply is closer to the EX-A1 than it is to the PLC:
  - Install and connect the power-line filter as close as possible to the EX-A1. The maximum wire length is 10 cm. Please refer to the filter manufacturer documentation for installation information.
  - Create 0V and 24V junctions at the EX-A1 respective terminals (see the following figure) and directly connect the EX-A1 main supply lines to the PLC.
  - Split the supply lines at the EX-A1 terminals and continue daisy-chaining them to the expansion I/O units.

**Please ensure that the wire segment which carries the 0V between the EX-A1 and the PLC does not branch.**

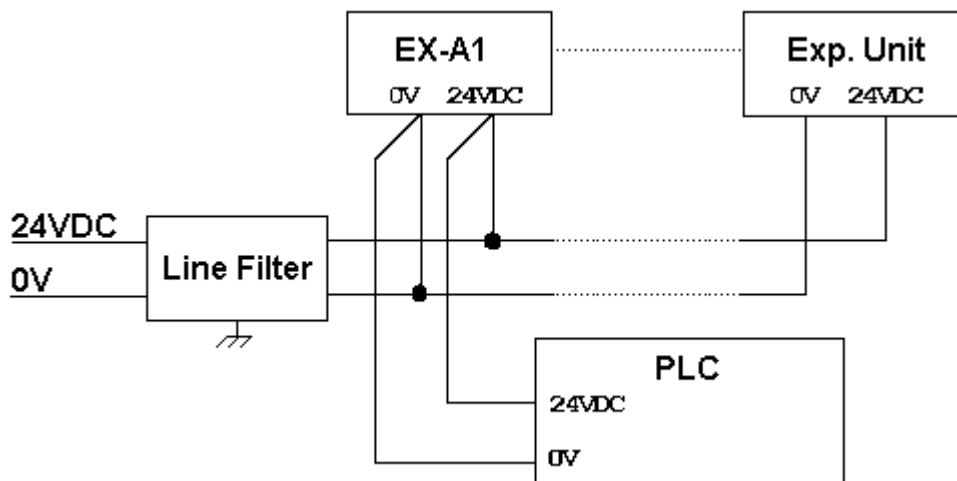

***EX-A1 Connected First (when power-supply is near the EX-A1)***

## Connecting the EX-A1 Communication Cable:

- Note that the communication cable is ended by RJ45 plugs. The plug comprising a yellow-green grounding wire must be connected to the PLC as shown in the following figure.
- This yellow-green wire must be grounded to the metal door panel or cabinet body (which must be also well grounded) using a screw. There cannot be any paint or other non-conductive coating between the wire terminal and metal as this may cause poor conduction.  
**DO NOT extend the wire.**

