

M90-R2-CAN

10 digital inputs, 2 analog inputs, high-speed counter/shaft encoder input, 6 relay outputs, I/O expansion port, RS232 plus CANbus

Power supply	24VDC
Permissible range	20.4 to 28.8VDC
Maximum current consumption	140mA @ 24VDC
Typical power consumption	3.2W @ 24VDC
Digital inputs	10 pnp (source) inputs
Nominal input voltage	24 VDC
Input voltage	< 5 VDC for Logic '0' > 15 VDC for Logic '1'
Input current	3 mA @ 24 VDC
Input impedance	8.4kΩ
Response time	(except Input#8 and Input#9) 5 mS
'0' to '1'	10 mS
'1' to '0'	
Galvanic isolation	None
Input cable length	Up to 100 meters, unshielded
High-speed counter	<ul style="list-style-type: none"> Input#9 can be used as either a digital input, or as a counter Input#8 can be used as either a digital input or as a counter reset Inputs#8 and #9 can also be used as a shaft encoder
Resolution	16-bit
Input frequency	Input#8 and input#9 : 5kHz max.
Minimum pulse width	Input#8 and input#9 : 80μs
Analog inputs	Two 10-bit, multi-range inputs: 0-5V or 0-10V for Vin0 0-10V for Vin1
Conversion method	Successive approximation
Input impedance	>100kΩ
Galvanic isolation	None
Resolution	10-bit (1024 units)
Conversion time	Synchronized to scan time
Absolute max. rating	± 15V
Full scale error	± 2 LSB
Linearity error	± 2 LSB
Digital outputs	6 relay outputs, 230VAC / 24 VDC
Output type	SPST-NO relay
Type of relay	Takamisawa JY-24H-K, or NAIS (Matsushita) JQ1AP-24V or OMRON G 6B - 1114P - 24VDC
Isolation	by relay

Output current	5A max. (resistive load) 1A max. (inductive load)
Max. frequency	10Hz
Contact protection	External precautions required
Display	STN, LCD display
Illumination	LED yellow-green backlight
Display size	1 line, 16 characters long
Character size	5 x 7 matrix, 3.07 x 5.73mm
Keypad	Sealed membrane
Number of keys	15
PLC program	2048 words
Bits/Coils	256
Integers/Registers	256
Timers	64
Execution time	12μsec. for bit operations
HMI displays	80 user-designed displays
HMI variables	50 HMI variables are available to conditionally display and modify text, numbers, dates, times & timer values. The user can also create a list of up to 120 variable text displays, totaling up to 2K.
RS232 serial port	
Programming	Download user program
Network option	Via RS485/RS232 converter
CANbus	Up to 64 nodes
Baud rate range	1Kbps - 1Mbps
Cable length	25m-1000m
I/O expansion port	Up to 64 additional I/Os, including: digital & analog I/Os, RTD and more.
Miscellaneous	
Clock (RTC)	Date and time-year 2000 compliant, with typical 7 years battery back-up
Weight	280g (9.8 oz.)
Temperature	Operational 0 to +50°C Storage -20 to +60°C
Mounting method	DIN-rail mounted (IP20) Panel mounted (IP65)

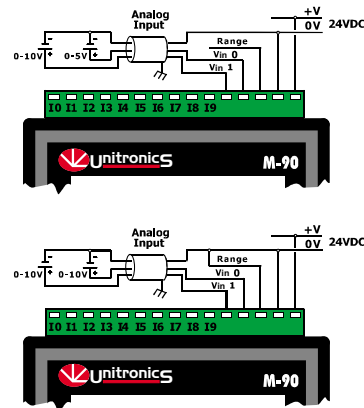
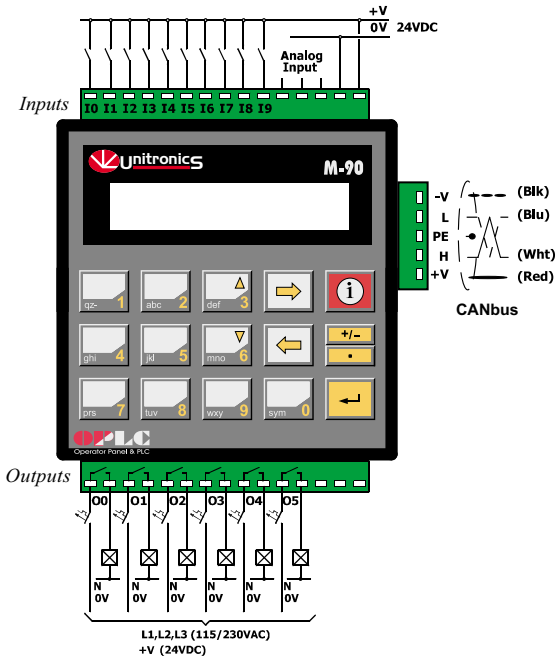

Analog-In Wiring