

V130-33-B1/V130-J-B1
 V350-35-B1/V350-J-B1
 V430-J-B1

General Description

The products listed above are micro-PLC+HMIs, rugged programmable logic controllers that comprise built-in operating panels.

Detailed Installation Guides containing the I/O wiring diagrams for these models, technical specifications, and additional documentation are located in the Technical Library in the Unitronics website:

<https://unitronicsplc.com/support-technical-library/>



Item	V130-B1 V130J-B1		V350-B1 V350J-B1		V430J-B1
Screen	2.4"		3.5" Color Touch		4.3" Color Touch
Keypad	Yes		None		
Function Keys	None		Yes		
Com Port, Built-in					
RS232/485	Yes	Yes	Yes*	Yes*	Yes*
USB device, mini-B	None	None	Yes*	Yes*	Yes*
Com Ports, separate order, user-installed	The user may install a CANbus port (V100-17-CAN), and one of the following: <ul style="list-style-type: none"> • RS232/RS485 port (V100-17-RS4/V100-17-RS4X) • Ethernet (V100-17-ET2) • Profibus Slave (V100-17-PB1) 				
* V430J/V350/V350J comprises both RS232/485 and USB ports; note that only one channel may be used at a time.					

Standard Kit Contents

Item	V130-B1 V130J-B1	V350-B1 V350J-B1	V430J-B1
Controller	Yes		
Terminal Blocks	Yes		
Battery (installed)	Yes		
Slides (2 sets of key labels)	None	Yes	None
Mounting Brackets	Yes (2 parts)		Yes (4 parts)
Rubber Seal	Yes		

Alert Symbols and General Restrictions

When any of the following symbols appear, read the associated information carefully.

Symbol	Meaning	Description
	Danger	The identified danger causes physical and property damage.
	Warning	The identified danger could cause physical and property damage.
<i>Caution</i>	Caution	Use caution.

- Before using this product, the user must read and understand this document.
- All examples and diagrams are intended to aid understanding, and do not guarantee operation. Unitronics accepts no responsibility for actual use of this product based on these examples.
- Please dispose of this product according to local and national standards and regulations.
- Only qualified service personnel should open this device or carry out repairs.

 Failure to comply with appropriate safety guidelines can cause severe injury or property damage.

 Do not attempt to use this device with parameters that exceed permissible levels.
 ▪ To avoid damaging the system, do not connect/disconnect the device when power is on.

Environmental Considerations

 Do not install in areas with: excessive or conductive dust, corrosive or flammable gas, moisture or rain, excessive heat, regular impact shocks or excessive vibration, in accordance with the standards given in the product's technical specification sheet.

- Do not place in water or let water leak onto the unit.
- Do not allow debris to fall inside the unit during installation.

 Ventilation: 10mm space required between controller's top/bottom edges & enclosure walls.
 ▪ Install at maximum distance from high-voltage cables and power equipment.

Mounting

Note that figures are for illustrative purposes only.

Dimensions: V130/V350/V130J/V350J

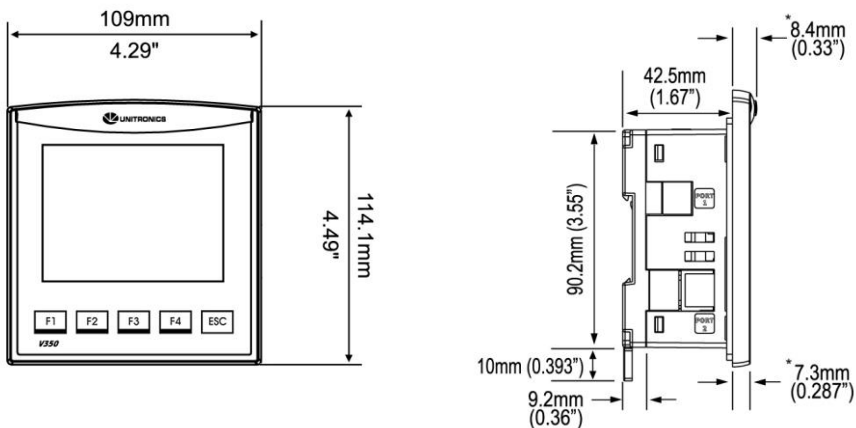

* Note that for models V130J/V350J, the bezel width is 6.7 mm (0.26").

Dimensions: V430J

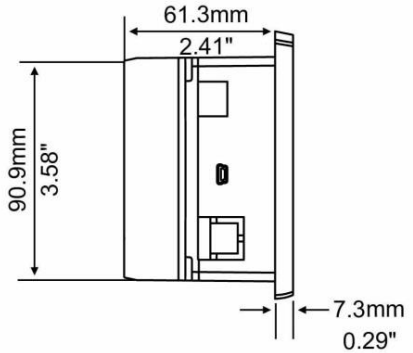
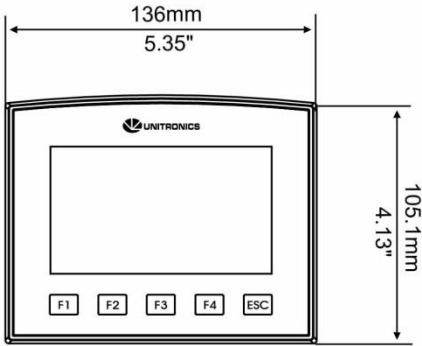

Model	Cut-out	View area
V130/V130J	92x92 mm (3.622"x3.622")	58x30.5mm (2.28"x1.2")
V350/V350J	92x92 mm (3.622"x3.622")	72x54.5mm (2.95"x2.14")
V430J	122.5x91.5 mm (4.82"x3.6")	96.4x55.2mm (3.79"x2.17")

Panel Mounting

Before you begin, note that the mounting panel cannot be more than 5 mm thick.

1. Make a panel cut-out of the appropriate size:
2. Slide the controller into the cut-out, ensuring that the rubber seal is in place.
3. Push the mounting brackets into their slots on the sides of the panel as shown in the figure below.
4. Tighten the bracket's screws against the panel. Hold the bracket securely against the unit while tightening the screw.
5. When properly mounted, the controller is squarely situated in the panel cut-out as shown in the accompanying figures.

V130/V350/V130J/V350J

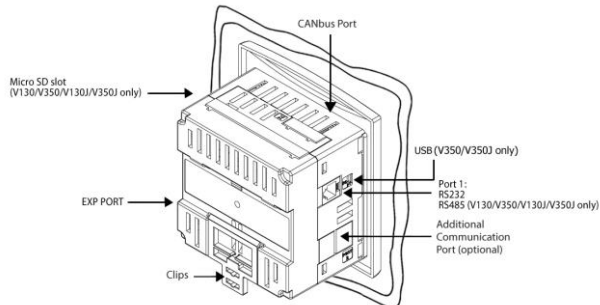
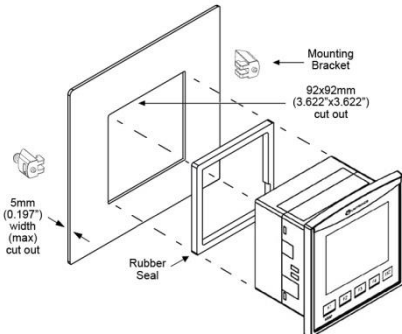

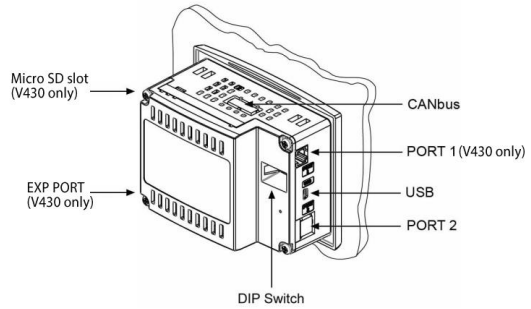
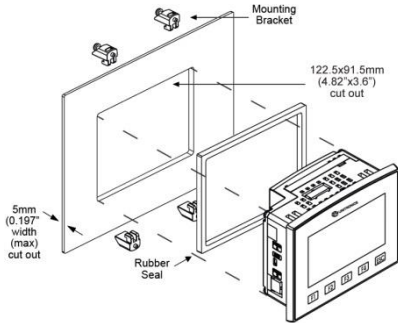
V430J**DIN-rail Mounting (V130/V350/V130J/V350J)**

1. Snap the controller onto the DIN rail as shown in the figure to the right.

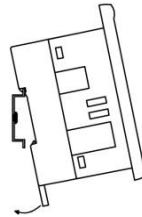

2. When properly mounted, the controller is squarely situated on the DIN-rail as shown in the figure to the right.

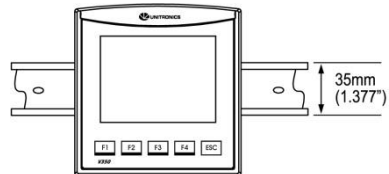
**UL Compliance**

The following section is relevant to Unitronics' products that are listed with the UL.

The following models: V130-33-R34, V130-J-R34, V130-T4-ZK1, V350-35-RA22, V350-J-RA22, V350-35-R34, V350-J-R34, V430-J-R34 are UL listed for Hazardous Locations.

The following models: V130-33-B1, V130-J-B1, V130-33-TA24, V130-J-TA24, V130-33-T38, V130-J-T38, V130-33-TR20, V130-J-TR20, V130-33-TR34, V130-J-TR34, V130-33-RA22, V130-J-RA22, V130-33-TRA22, V130-J-TRA22, V130-33-T2, V130-J-T2, V130-33-TR6, V130-J-TR6, V130-33-R34, V350-35-B1, V130-T4-ZK1, V350-J-B1, V350-35-TA24, V350-J-TA24, V350-35-T38, V350-J-T38, V350-35-TR20, V350-J-TR20, V350-35-TR34, V350-J-TR34, V350-35-TRA22, V350-J-TRA22, V350-35-T2, V350-J-T2, V350-35-TR6, V350-J-TR6, V350-S-TA24, V350-JS-TA24, V350-35-RA22,

V350-J-RA22,V350-35-R34, V430-J-B1,V430-J-TA24,V430-J-T38, V430-J-R34,V430-J-RH2, V430-J-TR34,V430-J-RA22,V430-J-TRA22,V430-J-T2,V430-J-RH6 are UL listed for Ordinary Location.

For models from series V130, V130-J, V430, that include “T4” or “J4” in the Model name, Suitable for mounting on the flat surface of Type 4X enclosure.
For examples: V130-T4-R34, V130-J4-R34, V430-J4-T2

UL Ordinary Location

In order to meet the UL ordinary location standard, panel-mount this device on the flat surface of Type 1 or 4 X enclosures

UL Ratings, Programmable Controllers for Use in Hazardous Locations,

Class I, Division 2, Groups A, B, C and D

These Release Notes relate to all Unitronics products that bear the UL symbols used to mark products that have been approved for use in hazardous locations, Class I, Division 2, Groups A, B, C and D.

Caution

- This equipment is suitable for use in Class I, Division 2, Groups A, B, C and D, or Non-hazardous locations only.
- Input and output wiring must be in accordance with Class I, Division 2 wiring methods and in accordance with the authority having jurisdiction.
-  **WARNING—Explosion Hazard—**substitution of components may impair suitability for Class I, Division 2.
- **WARNING – EXPLOSION HAZARD –** Do not connect or disconnect equipment unless power has been switched off or the area is known to be non-hazardous.
- **WARNING –** Exposure to some chemicals may degrade the sealing properties of material used in Relays.
- This equipment must be installed using wiring methods as required for Class I, Division 2 as per the NEC and/or CEC.

Panel-Mounting

For programmable controllers that can be mounted also on panel, in order to meet the UL Haz Loc standard, panel-mount this device on the flat surface of Type 1 or Type 4X enclosures.

Relay Output Resistance Ratings

The products listed below contain relay outputs:

Programmable controllers, Models: V430-J-R34, V130-33-R34,V130-J-R34 and V350-35-R34, V350-J-R34

- When these specific products are used in hazardous locations, they are rated at 3A res.
- Except for models V430-J-R34, V130-33-R34, V130-J-R34, V130-T4-ZK1 and V350-35-R34, V350-J-R34,when these specific products are used in non-hazardous environmental conditions, they are rated at 5A res, as given in the product's specifications.

Communication and Removable Memory Storage

When products comprise either USB communication port, SD card slot, or both, neither the SD card slot nor the USB port are intended to be permanently connected, while the USB port is intended for programming only.

Removing / Replacing the battery

When a product has been installed with a battery, do not remove or replace the battery unless the power has been switched off, or the area is known to be non-hazardous.



Please note that it is recommended to back up all data retained in RAM, in order to avoid losing data when changing the battery while the power is switched off. Date and time information will also need to be reset after the procedure.

UL des zones ordinaires:

Pour respecter la norme UL des zones ordinaires, monter l'appareil sur une surface plane de type de protection 1 ou 4X

Certification UL des automates programmables, pour une utilisation en environnement à risques, Class I, Division 2, Groups A, B, C et D.

Cette note fait référence à tous les produits Unitronics portant le symbole UL - produits qui ont été certifiés pour une utilisation dans des endroits dangereux, Classe I, Division 2, Groupes A, B, C et D.

-
- Attention* ■ Cet équipement est adapté pour une utilisation en Classe I, Division 2, Groupes A, B, C et D, ou dans Non-dangereux endroits seulement.
-  ■ Le câblage des entrées/sorties doit être en accord avec les méthodes de câblage selon la Classe I, Division 2 et en accord avec l'autorité compétente.
-  ■ AVERTISSEMENT: Risque d'Explosion – Le remplacement de certains composants rend caduque la certification du produit selon la Classe I, Division 2.
- AVERTISSEMENT - DANGER D'EXPLOSION - Ne connecter pas ou ne débranche pas l'équipement sans avoir préalablement coupé l'alimentation électrique ou la zone est reconnue pour être non dangereuse.
- AVERTISSEMENT - L'exposition à certains produits chimiques peut dégrader les propriétés des matériaux utilisés pour l'étanchéité dans les relais.
- Cet équipement doit être installé utilisant des méthodes de câblage suivant la norme Class I, Division 2 NEC et /ou CEC.
-

Montage de l'écran:

Pour les automates programmables qui peuvent aussi être monté sur l'écran, pour pouvoir être au standard UL, l'écran doit être monté dans un coffret avec une surface plane de type 1 ou de type 4X.

Certification de la résistance des sorties relais

Les produits énumérés ci-dessous contiennent des sorties relais:

- Automates programmables, modèles : V430-J-R34, V130-33-R34, V130-J-R34 and V350-35-R34, V350-J-R34
- Lorsque ces produits spécifiques sont utilisés dans des endroits dangereux, ils supportent un courant de 3A charge résistive.
- Excepté les modèles: V430-J-R34, V130-33-R34, V130-J-R34, V130-T4-ZK1 et V350-35-R34, V350-J-R34 lorsque ces produits spécifiques sont utilisés dans un environnement non dangereux, ils sont évalués à 5A res, comme indiqué dans les spécifications du produit Plages de températures

Communication et de stockage amovible de mémoire (carte mémoire)

Produits comprend un port USB de communication, soit un port carte SD ou les deux, ni le port SD, ni le port USB ne sont censés être utilisés en permanence, tandis que l'USB est destiné à la programmation uniquement.

Retrait / Remplacement de la batterie

Lorsqu'un produit a été installé avec une batterie, retirez et remplacez la batterie seulement si l'alimentation est éteinte ou si l'environnement n'est pas dangereux.

Veillez noter qu'il est recommandé de sauvegarder toutes les données conservées dans la RAM, afin d'éviter de perdre des données lors du changement de la batterie lorsque l'alimentation est coupée. Les informations sur la date et l'heure devront également être réinitialisées après la procédure

Wiring



- Do not touch live wires.
-



- Install an external circuit breaker. Guard against short-circuiting in external wiring.
 - Use appropriate circuit protection devices.
 - Unused pins should not be connected. Ignoring this directive may damage the device.
 - Double-check all wiring before turning on the power supply.
-

Caution

- To avoid damaging the wire, do not exceed a maximum torque of 0.5 N·m (5 kgf·cm).
 - Do not use tin, solder, or any substance on stripped wire that might cause the wire strand to break.
 - Install at maximum distance from high-voltage cables and power equipment.
-

Wiring Procedure

Use crimp terminals for Use crimp terminals for wiring;

- Controllers offering a terminal block with pitch of 5mm: 26-12 AWG wire (0.13 mm² –3.31 mm²).
- Controllers offering a terminal block with pitch of 3.81mm: 26-16 AWG wire (0.13 mm² – 1.31 mm²).

1. Strip the wire to a length of 7±0.5mm (0.270–0.300").
2. Unscrew the terminal to its widest position before inserting a wire.
3. Insert the wire completely into the terminal to ensure a proper connection.
4. Tighten enough to keep the wire from pulling free.

- Input or output cables should not be run through the same multi-core cable or share the same wire.
- Allow for voltage drop and noise interference with I/O lines used over an extended distance. Use wire that is properly sized for the load.
- The controller and I/O signals must be connected to the same 0V signal.

Power Supply

The picture is for illustration only.

The controller requires an external 12VDC or 24VDC power supply.



- The power supply must include double insulation. Outputs must be rated as SELV/PELV/Class2/Limited Power.

- Use separate wires to connect the functional earth line (pin 3) and the 0V line (pin 2) to the system earth ground.
- Install an external circuit breaker. Guard against short-circuiting in external wiring.
- Double-check all wiring before turning on the power supply.
- Do not connect either the 'Neutral' or 'Line' signal of the 110/220VAC to device's 0V pin
- In the event of voltage fluctuations or non-conformity to voltage power supply specifications, connect the device to a regulated power supply.

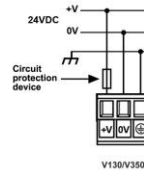
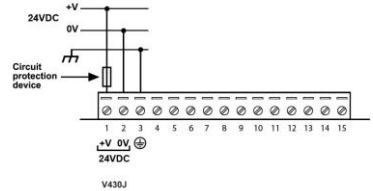

Earthing the PLC+HMI

To maximize system performance, avoid electromagnetic interference by:

- Mounting the controller on a metal panel.
- Connect each common and ground connection directly to the earth ground of your system.
- For ground wiring uses the shortest and thickest possible wire.

Communication

- **V130/ V130J**
These models comprise a built-in RS232/RS485 serial port (Port 1)
- **V430J/ V350/V350J**
These models comprise built-in ports: 1 USB and 1 RS232/RS485 (Port 1).

Note that physically connecting a PC to the controller via USB suspends RS232/RS485 communications via Port 1. When the PC is disconnected, RS232/RS485 resumes.

RS232/RS485 Port



- Turn off power before making communications connections.

Caution ▪ Always use the appropriate port adapters.

- Signals are related to the controller's 0V; the same 0V is used by the power supply.

Caution ▪ The serial port is not isolated. If the controller is used with a non-isolated external device, avoid potential voltage that exceeds $\pm 10V$.

- Use RS232 to download programs from a PC, and to communicate with serial devices and applications, such as SCADA.
- Use RS485 to create a multi-drop network containing up to 32 devices.

Pinouts

The pinouts below show the PLC port signals.

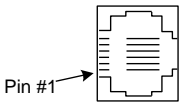
RS232		RS485**		Controller Port 
Pin #	Description	Pin #	Description	
1*	DTR signal	1	A signal (+)	
2	0V reference	2	(RS232 signal)	
3	TXD signal	3	(RS232 signal)	
4	RXD signal	4	(RS232 signal)	
5	0V reference	5	(RS232 signal)	
6*	DSR signal	6	B signal (-)	

* Standard programming cables do not provide connection points for pins 1 and 6.

** When a port is adapted to RS485, Pin 1 (DTR) is used for signal A, and Pin 6 (DSR) signal is used for signal B.

Note that it is possible to establish a PC to PLC connection using RS232 even when the PLC is set to RS485 (this eliminates the need to open the controller to set jumpers).

To do so, remove the RS485 connector (pins 1 & 6) from the PLC and connect a standard RS232 programming cable.

Note that this is possible only if DTR and DSR signals of RS232 are not used (which is the standard case).

Setting RS232/RS485 Communication Parameters, V130/V350/V130J/V350J

This port may be set to either RS232 or RS485 via jumper. The accompanying figure shows the jumper factory default settings.

These jumpers may be used to:

- Set communications to RS485, by setting both COMM jumpers to '485'.
- Set RS485 termination, by setting both TERM jumpers to 'OFF'.

To access the jumpers, you must open the controller according to the instructions on page 8.

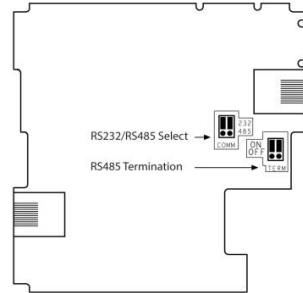

Setting RS232/RS485 Communication Parameters, V430J

This port may be set to either RS232 or RS485 via DIP switches:

The table shows the DIP switches factory default settings. Use the table to adapt the settings.

	Switch Settings					
	1	2	3	4	5	6
RS232*	ON	OFF	OFF	ON	OFF	OFF
RS485	OFF	ON	ON	OFF	OFF	OFF
RS485 with termination**	OFF	ON	ON	OFF	ON	ON

* Default factory setting

** Causes the unit to function as an end unit in an RS485 network

USB Port

Caution ▪ The USB port is not isolated.
Make sure that the PC and the controller are grounded to same potential.

The USB port may be used for programming, OS download, and PC access.

Opening the Controller (V130/V350/V130J/V350J Only)



- Before performing these actions, touch a grounded object to discharge any electrostatic charge.
- Avoid touching the PCB board directly. Hold the PCB board by its connectors.

1. Turn off the power supply, disconnect, and dismount the controller.
2. The back cover of the controller comprises 4 screws, located in the corners.
Remove the screws, and pull off the back cover.

Changing Communication Settings (V130/V350/V130J/V350J Only)

1. To access the communication jumpers, hold the Power supply PCB board by its edges and steadily pull the board off.
2. Locate the jumpers, and then change the settings as required, according to the jumpers' settings shown on page 7.

Closing the Controller (V130/V350/V130J/V350J Only)

1. Gently replace the board. Make certain that the pins fit correctly into their matching receptacle.
Do not force the board into place; doing so may damage the controller.
2. Replace the back cover of the controller and fasten the corner screws.

Note that you must replace the back cover securely before powering up the controller.

Vision™ PLC+HMI

V130-33-B1/V130-J-B1 V350-35-B1/V350-J-B1 V430-J-B1 Technical Specifications

Order Information

Item

V130-33-B1	PLC with Classic panel, Monochrome display 2.4"
V130-J-B1	PLC with Flat panel, Monochrome display 2.4"
V350-35-B1	PLC with Classic panel, Color touch display 3.5"
V350-J-B1	PLC with Flat panel, Color touch display 3.5"
V430-J-B1	PLC with Flat panel, Color touch display 4.3"

You can find additional information, such as wiring diagrams, in the product's installation guide located in the Technical Library at www.unitronics.com.

Power Supply

Item	V130-B1 V130J-B1	V350-B1 V350J-B1	V430J-B1
Input voltage	12VDC or 24VDC		
Permissible range	10.2VDC to 28.8VDC with less than 10% ripple		
Max. current consumption	See Note 1		
	200mA@12VDC	220mA@12VDC	220mA@12VDC
	100mA@24VDC	110mA@24VDC	110mA@24VDC

Notes:

- To calculate the actual power consumption, subtract the current for each unused element from the maximum current consumption value according to the values below:

	Input voltage	Backlight	Ethernet card
V130/J	12V	20mA	70mA
V350/J/V430J		40mA	70mA
V130/J	24V	10mA	35mA
V350/J/V430J		20mA	35mA

Graphic Display Screen

Item	V130-B1 V130J-B1	V350-B1 V350J-B1	V430J-B1
LCD Type	STN, LCD display	TFT, LCD display	TFT, LCD display
Illumination backlight	White LED	White LED	White LED
Display resolution	128x64 pixels	320x240 pixels	480x272 pixels
Viewing area	2.4"	3.5"	4.3"
Colors	Monochrome	65,536 (16-bit)	65,536 (16-bit)
Screen Contrast	Via software (Store value to SI 7, values range: 0 to 100%)	Fixed	Fixed
Touchscreen	None	Resistive, analog	Resistive, analog
'Touch' indication	None	Via buzzer	Via buzzer
Screen brightness control	Via software (Store value to SI 9, 0 = Off, 1 = On)	Via software (Store value to SI 9, values range: 0 to 100%)	
Virtual Keypad	None	Displays virtual keyboard when the application requires data entry.	

Keypad

Item	V130-B1 V130J-B1	V350-B1 V350J-B1	V430J-B1
Number of keys	20 keys, including 10 user-labeled keys	5 programmable function keys	
Key type	Metal dome, sealed membrane switch		
Slides	Slides may be installed in the operating panel faceplate to custom-label the keys. Refer to <i>V130 Keypad Slides.pdf</i> . A complete set of blank slides is available by separate order	Slides may be installed in the operating panel faceplate to custom-label the keys. Refer to <i>V350 Keypad Slides.pdf</i> . Two sets of slides are supplied with the controller: one set of arrow keys, and one blank set.	None

Program

Item	V130-B1 V130J-B1	V350-B1 V350J-B1	V430J-B1
Memory size			
Application Logic	512KB	1MB	1MB
Images	128KB	6MB	12MB
Fonts	128KB	512KB	512KB

Item	Quantity		Symbol	Value
	V130-B1 V130J-B1	V350-B1 V350J-B1 V430J-B1		
Memory Bits	4096	8192	MB	Bit (coil)
Memory Integers	2048	4096	MI	16-bit signed/unsigned
Long Integers	256	512	ML	32-bit signed/unsigned
Double Word	64	256	DW	32-bit unsigned
Memory Floats	24	64	MF	32-bit signed/unsigned
Fast Bits	1024	1024	XB	Fast Bits (coil) – not retained
Fast Integers	512	512	XI	16 bit signed/unsigned (fast, not retained)
Fast Long Integers	256	256	XL	32 bit signed/unsigned (fast, not retained)
Fast Double Word	64	64	XDW	32 bit unsigned (fast, not retained)
Timers	192	384	T	Res. 10 ms; max 99h, 59 min, 59.99s
Counters	24	32	C	32-bit

Data Tables 120K dynamic data (recipe parameters, datalogs, etc.)
 192K fixed data (read-only data, ingredient names, etc)
 Expandable via SD card. See Removable Memory below

HMI displays Up to 1024

Program scan time	20µs per 1kb of typical application	15µs per 1kb of typical application
-------------------	-------------------------------------	-------------------------------------

Removable Memory

Micro SD card	Compatible with standard SD and SDHC; up to 32GB store datalogs, Alarms, Trends, Data Tables, backup Ladder, HMI, and OS. See Note 2
---------------	---

Notes:

2. User must format via Unitronics SD tools utility.

Communication Ports

Port 1	1 channel, RS232/RS485 and USB device (V430/V350/V350J only). See Note 3
Galvanic isolation	No
Baud rate	300 to 115200 bps
RS232	
Input voltage	±20VDC absolute maximum
Cable length	15m maximum (50')
RS485	
Input voltage	-7 to +12VDC differential maximum
Cable type	Shielded twisted pair, in compliance with EIA 485
Cable length	1200m maximum (4000')
Nodes	Up to 32
USB device (V430/V350/V350J only)	
Port type	Mini-B, See Note 5
Specification	USB 2.0 compliant; full speed
Cable	USB 2.0 compliant; up to 3m
Port 2 (optional)	See Note 4
CANbus (optional)	See Note 4

Notes:

3. This model is supplied with a serial port: RS232/RS485 (Port 1). The standard is set to either RS232 or RS485 according to jumper settings. Refer to the product's Installation Guide.
4. The user may order and install one or both of the following modules:
 - An additional port (Port 2). Available port types: RS232/RS485 isolated/non-isolated, Ethernet
 - A CANbus port
 Port module documentation is available on the Unitronics website.
5. Note that physically connecting a PC to the controller via USB suspends RS232/RS485 communications via Port 1. When the PC is disconnected, RS232/RS485 resumes.

I/O Expansion

	Additional I/Os may be added. Configurations vary according to module. Supports digital, high-speed, analog, weight and temperature measurement I/Os.
Local	Via I/O Expansion Port. Integrate up to 8 I/O Expansion Modules comprising up to 128 additional I/Os. Adapter required (P.N. EX-A2X).
Remote	Via CANbus port. Connect up to 60 adapters to a distance of 1000 meters from controller; and up to 8 I/O expansion modules to each adapter (up to a total of 512 I/Os). Adapter required (P.N. EX-RC1).

Miscellaneous

Clock (RTC)	Real-time clock functions (date and time)
Battery back-up	7 years typical at 25°C, battery back-up for RTC and system data, including variable data
Battery replacement	Yes. Coin-type 3V, lithium battery, CR2450

Dimensions

Item		V130-B1 V130J-B1	V350-B1 V350J-B1	V430J-B1
Size	Vxxx	109 x 114.1 x 68mm (4.29 x 4.49 x 2.67"). See Note 6	109 x 114.1 x 68mm (4.29 x 4.49 x 2.67"). See Note 6	
	Vxxx-J	109 x 114.1 x 66mm (4.92 x 4.49 x 2.59"). See Note 6	109 x 114.1 x 66mm (4.92 x 4.49 x 2.59"). See Note 6	136 x 105.1 x 61.3mm (5.35 x 4.13 x 2.41"). See Note 6
Weight		255g (9 oz)	270g (9.5 oz)	300g (10.5 oz)

Notes:

6. For exact dimensions, refer to the product's Installation Guide.

Environment

Operational temperature	0 to 50°C (32 to 122°F)
Storage temperature	-20 to 60°C (-4 to 140°F)
Relative Humidity (RH)	10% to 95% (non-condensing)
Mounting method	Panel mounted (IP65/66/NEMA4X) DIN-rail mounted (IP20/NEMA1)
Operating Altitude	2000m (6562 ft)
Shock	IEC 60068-2-27, 15G, 11ms duration
Vibration	IEC 60068-2-6, 5Hz to 8.4Hz, 3.5mm constant amplitude, 8.4Hz to 150Hz, 1G acceleration.

The information in this document reflects products at the date of printing. Unitronics reserves the right, subject to all applicable laws, at any time, at its sole discretion, and without notice, to discontinue or change the features, designs, materials and other specifications of its products, and to either permanently or temporarily withdraw any of the forgoing from the market.

All information in this document is provided "as is" without warranty of any kind, either expressed or implied, including but not limited to any implied warranties of merchantability, fitness for a particular purpose, or non-infringement. Unitronics assumes no responsibility for errors or omissions in the information presented in this document. In no event shall Unitronics be liable for any special, incidental, indirect or consequential damages of any kind, or any damages whatsoever arising out of or in connection with the use or performance of this information.

The tradenames, trademarks, logos and service marks presented in this document, including their design, are the property of Unitronics (1989) (R'G) Ltd. or other third parties and you are not permitted to use them without the prior written consent of Unitronics or such third party as may own them