

The IO-DI8-TO8 and IO-DI8-TO8-L are I/O expansion modules that can be used in conjunction with specific Unitronics OPLC controllers.

The modules are identical except for their voltage specifications: IO-DI8-TO8 runs at 24 VDC; IO- DI8-TO8-L at 12 VDC.

Both modules offer 8 digital inputs, type pnp/npn (source/sink), and 8 pnp (source) transistor outputs.

The interface between a module and the OPLC is provided by an adapter.

These modules may either be snap-mounted on a DIN rail, or screw-mounted onto a mounting plate.

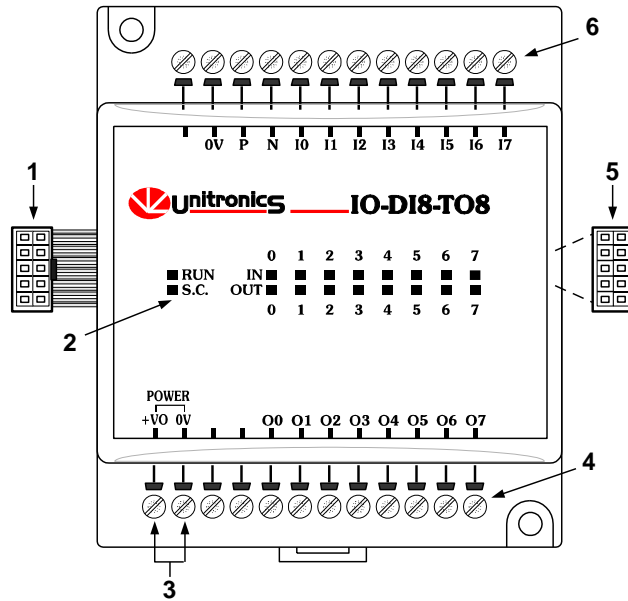

Component identification

1	Module-to-module connector
2	Status indicators
3	Connection points for power supply to outputs
4	Output connection points
5	Module-to-module connector port
6	Input connection points

- Before using this product, it is the responsibility of the user to read and understand this document and any accompanying documentation.
- All examples and diagrams shown herein are intended to aid understanding, and do not guarantee operation. Unitronics accepts no responsibility for actual use of this product based on these examples.
- Please dispose of this product in accordance with local and national standards and regulations.
- Only qualified service personnel should open this device or carry out repairs.

User safety and equipment protection guidelines

This document is intended to aid trained and competent personnel in the installation of this equipment as defined by the European directives for machinery, low voltage, and EMC. Only a technician or engineer trained in the local and national electrical standards should perform tasks associated with the device's electrical wiring.

Symbols are used to highlight information relating to the user's personal safety and equipment protection throughout this document. When these symbols appear, the associated information must be read carefully and understood fully.

Symbol	Meaning	Description
	Danger	The identified danger causes physical and property damage.
	Warning	The identified danger can cause physical and property damage.
Caution	Caution	Use caution.



- Failure to comply with appropriate safety guidelines can result in severe personal injury or property damage. Always exercise proper caution when working with electrical equipment.



- Check the user program before running it.
- Do not attempt to use this device with parameters that exceed permissible levels.
- Install an external circuit breaker and take appropriate safety measures against short-circuiting in external wiring.
- To avoid damaging the system, do not connect / disconnect the device when the power is on.

Environmental Considerations



- Do not install in areas with: excessive or conductive dust, corrosive or flammable gas, moisture or rain, excessive heat, regular impact shocks or excessive vibration.



- Leave a minimum of 10mm space for ventilation between the top and bottom edges of the device and the enclosure walls.
- Do not place in water or let water leak onto the unit.
- Do not allow debris to fall inside the unit during installation.

Mounting the Module

DIN-rail mounting

Snap the device onto the DIN rail as shown below; the module will be squarely situated on the DIN rail.

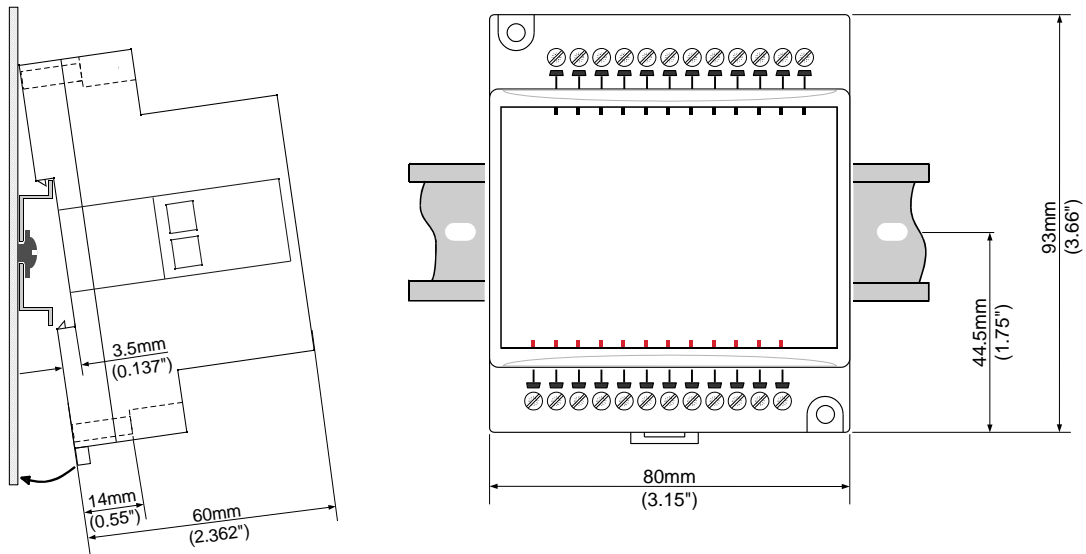

Screw-Mounting

The figure on the next page is drawn to scale. It may be used as a guide for screw-mounting the module.

Mounting screw type: either M3 or NC6-32.

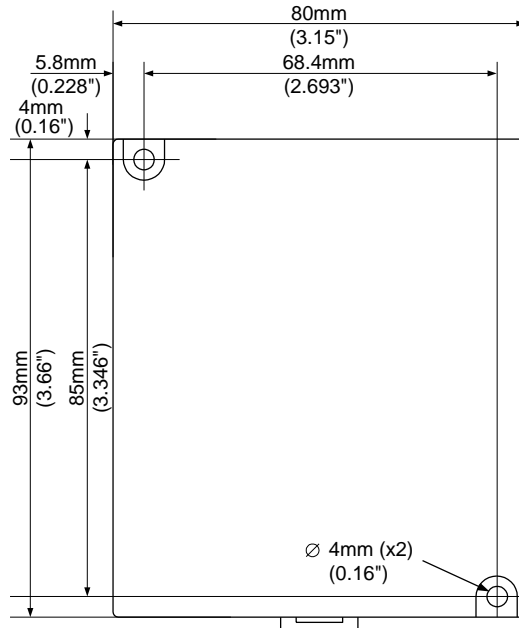

Connecting Expansion Modules

An adapter provides the interface between the OPLC and an expansion module. To connect the I/O module to the adapter or to another module:

1. Push the module-to-module connector into the port located on the right side of the device.

Note that there is a protective cap provided with the adapter. This cap covers the port of the final I/O module in the system.



- To avoid damaging the system, do not connect or disconnect the device when the power is on.

Component identification	
1	Module-to-module connector
2	Protective cap

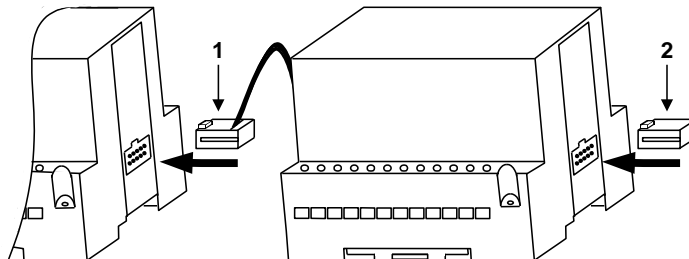

Wiring



- Do not touch live wires.



- Unused pins should not be connected. Ignoring this directive may damage the device.
- Do not connect the 'Neutral or 'Line' signal of the 110/220VAC to the device's 0V pin.
- Double-check all wiring before turning on the power supply.

Wiring Procedures

Use crimp terminals for wiring; use 26-12 AWG wire (0.13 mm²–3.31 mm²) for all wiring purposes.

1. Strip the wire to a length of 7±0.5mm (0.250–0.300 inches).
2. Unscrew the terminal to its widest position before inserting a wire.
3. Insert the wire completely into the terminal to ensure that a proper connection can be made.
4. Tighten enough to keep the wire from pulling free.

- To avoid damaging the wire, do not exceed a maximum torque of 0.5 N·m (5 kgf·m).
- Do not use tin, solder, or any other substance on stripped wire that might cause the wire strand to break.
- Install at maximum distance from high-voltage cables and power equipment.

I/O Wiring—General

- Input or output cables should not be run through the same multi-core cable or share the same wire.
- Allow for voltage drop and noise interference with input/output lines used over an extended distance. Use wire that is properly sized for the load.
- The adapter and I/O signals must be connected to the same 0V signal.

Digital I/Os

- Inputs may be wired as either pnp (source) or npn (sink) inputs.

npn (sink) inputs

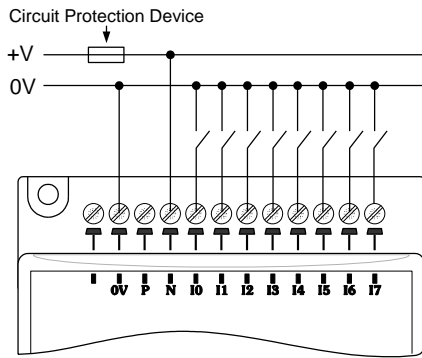

pnp (source) inputs

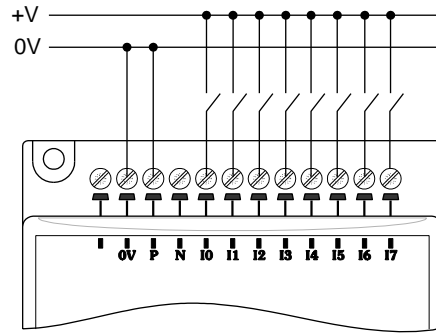

npn (sink) high-speed counter/frequency measurer

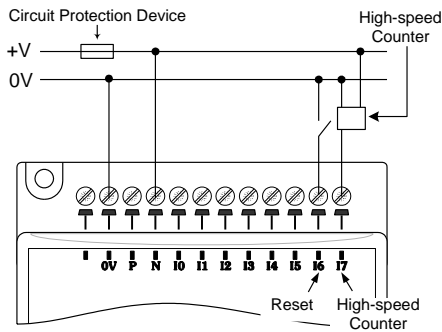

pnp (source) high-speed counter/frequency measurer

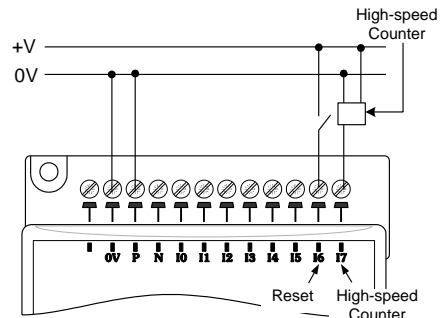

Wiring the Output's Power Supply

Wiring DC supply

- Connect the "positive" cable to the "+V0" terminal, and the "negative" to the "0V" terminal.
 - A non-isolated power supply can be used provided that a 0V signal is connected to the chassis.
 - Do not connect the 'Neutral or 'Line' signal of the 110/220VAC to the device's 0V pin.
 - In the event of voltage fluctuations or non-conformity to voltage power supply specifications, connect the device to a regulated power supply.

Outputs

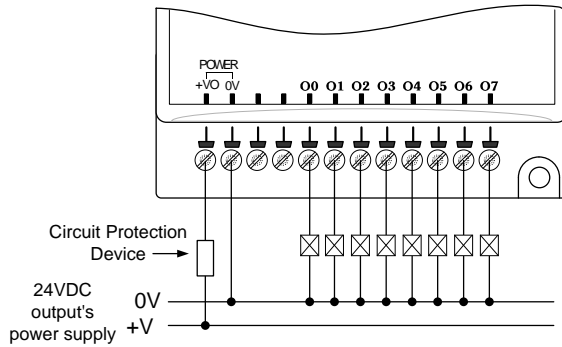

IO-DI8-TO8, IO-DI8-TO8-L Technical Specifications

Max. current consumption	70mA maximum from the adapter's 5VDC
Typical power consumption	0.15W @ 5VDC
Status indicator	
(RUN)	Green LED: —Lit when a communication link is established between module and OPLC. —Blinks when the communication link fails.

Inputs

Number of inputs	8 (in one group)	
Input type	pnp (source) or npn (sink)	
Galvanic isolation	None	
Status indicators	Green LEDs—Lit when the corresponding input is active. See Note 1.	
(IN)		
Nominal input voltage	24VDC for IO-DI8-TO8, 12VDC for IO-DI8-TO8-L	
Input voltage	IO-DI8-TO8	IO-DI8-TO8-L
pnp (source)	0-5VDC for Logic '0' 17-28.8VDC for Logic '1'	0-3VDC for Logic '0' 8-15.6V for Logic '1'
nnp (sink), voltage/current	17-28.8VDC/<1.1 mA for Logic '0' 0-5VDC/>4.3mA for Logic '1'	8-15.6VDC/<1.1 mA for Logic '0' 0-3VDC/>4.3mA for Logic '1'
Input current	6mA@24VDC	6mA@12VDC
Response time	10mSec typical	
Input #7	The specifications below apply when this input is wired for use as a high-speed counter input/frequency measurer. See Notes 2 and 3.	
Resolution	16-bit	
Frequency	5kHz maximum	
Minimum pulse width	80µs	

Outputs

Number of outputs	8 pnp (source)
Output type	P-MOSFET (open drain) for both 24VDC and 12VDC outputs
Galvanic isolation	None
Output current	0.5A maximum (per output) Total current: 3A maximum (all outputs)
Maximum frequency	20Hz (resistive load) 0.5 Hz (inductive load)
Short circuit protection	Yes
Status Indicators	
(OUT)	Red LEDs—Lit when the corresponding output is active.
(S.C)	Red LED—Lit when an output's load short-circuits. See Note 4 below.
Voltage	
Operating voltage	10.2 to 28.8VDC
Nominal operating voltage	12/24VDC

Environmental

Operating temperature	IP20 / NEMA1 0° to 50°C (32° to 122°F)
Storage temperature	-20° to 60° C (-4° to 140°F)
Relative Humidity (RH)	5% to 95% (non-condensing)
Dimensions (WxHxD)	80mm x 93mm x 60mm (3.15" x 3.66" x 2.362")
Weight	141g (4.9oz.)
Mounting	Either onto a 35mm DIN-rail or screw-mounted.

Notes:

1. The inputs' LEDs light up only when communication link is established between module and OPLC.
2. Input #7 can function either as a high-speed counter, a frequency measurer, or as a normal digital input. When Input #7 is used as a normal digital input, normal input specifications apply.
3. Input #6 can function either as the counter's reset, or as a normal digital input; in either case, its specifications are those of a normal digital input.
4. When an output is connected to a load that short-circuits, that output turns off and the S.C. LED lights up on the module. The short circuit is also identified by the software program within the controller connected to the module. Within the M90 OPLC, for example, SB 5 turns ON. SI 5 contains a bitmap indicating the module containing the affected output. For more information, refer to the on-line help supplied with the controller.

Addressing I/Os on Expansion Modules

Inputs and outputs located on I/O expansion modules that are connected to an OPLC are assigned addresses that comprise a letter and a number. The letter indicates whether the I/O is an input (I) or an output (O). The number indicates the I/O's location in the system. This number relates to both the position of the expansion module in the system, and to the position of the I/O on that module.

Expansion modules are numbered from 0-7 as shown in the figure below.

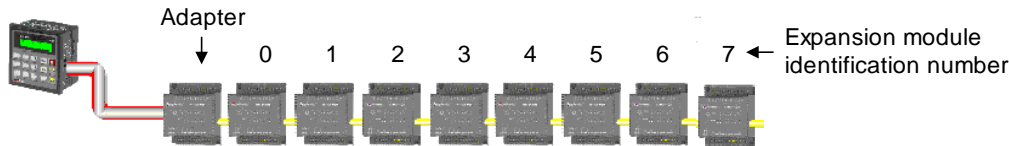

The formula below is used to assign addresses for I/O modules used in conjunction with the OPLC.

X is the number representing a specific module's location (0-7). Y is the number of the input or output on that specific module (0-15).

The number that represents the I/O's location is equal to:

$$32 + x \cdot 16 + y$$

Examples

- Input #3, located on expansion module #2 in the system, will be addressed as I 67, $67 = 32 + 2 \cdot 16 + 3$
- Output #4, located on expansion module #3 in the system, will be addressed as O 84, $84 = 32 + 3 \cdot 16 + 4$.

EX90-DI8-RO8 is a stand-alone I/O module. Even if it is the only module in the configuration, the EX90-DI8-RO8 is always assigned the number 7.

Its I/Os are addressed accordingly.

Example

- Input #5, located on an EX90-DI8-RO8 connected to an OPLC will be addressed as I 149, $149 = 32 + 7 \cdot 16 + 5$

UL Compliance

The following section is relevant to Unitronics' products that are listed with the UL.

The following models: IO-AI4-AO2, IO-AO6X, IO-ATC8, IO-DI16, IO-DI16-L, IO-DI8-RO4, IO-DI8-RO4-L, IO-DI8-TO8, IO-DI8-TO8-L, IO-RO16, IO-RO16-L, IO-RO8, IO-RO8L, IO-TO16, EX-A2X are UL listed for Hazardous Locations.

The following models: EX-D16A3-RO8, EX-D16A3-RO8L, EX-D16A3-TO16, EX-D16A3-TO16L, IO-AI1X-AO3X, IO-AI4-AO2, IO-AI4-AO2-B, IO-AI8, IO-AI8Y, IO-AO6X, IO-ATC8, IO-D16A3-RO16, IO-D16A3-RO16L, IO-D16A3-TO16, IO-D16A3-TO16L, IO-DI16, IO-DI16-L, IO-DI8-RO4, IO-DI8-RO4-L, IO-DI8-RO8, IO-DI8-RO8-L, IO-DI8-TO8, IO-DI8-TO8-L, IO-DI8ACH, IO-LC1, IO-LC3, IO-PT4, IO-PT400, IO-PT4K, IO-RO16, IO-RO16-L, IO-RO8, IO-RO8L, IO-TO16, EX-A2X, EX-RC1 are UL listed for Ordinary Location.

UL Ratings, Programmable Controllers for Use in Hazardous Locations,

Class I, Division 2, Groups A, B, C and D

These Release Notes relate to all Unitronics products that bear the UL symbols used to mark products that have been approved for use in hazardous locations, Class I, Division 2, Groups A, B, C and D.

- Caution*
- This equipment is suitable for use in Class I, Division 2, Groups A, B, C and D, or Non-hazardous locations only.
 - Input and output wiring must be in accordance with Class I, Division 2 wiring methods and in accordance with the authority having jurisdiction.
 - WARNING—Explosion Hazard—substitution of components may impair suitability for Class I, Division 2.
 - WARNING – EXPLOSION HAZARD – Do not connect or disconnect equipment unless power has been switched off or the area is known to be non-hazardous.
 - WARNING – Exposure to some chemicals may degrade the sealing properties of material used in Relays.

- This equipment must be installed using wiring methods as required for Class I, Division 2 as per the NEC and/or CEC.

Relay Output Resistance Ratings

The products listed below contain relay outputs:

Input/Output expansion modules, Models: IO-DI8-RO4, IO-DI8-RO4-L, IO-RO8, IO-RO8L

- When these specific products are used in hazardous locations, they are rated at 3A res, when these specific products are used in non-hazardous environmental conditions, they are rated at 5A res, as given in the product's specifications.

Certification UL des automates programmables, pour une utilisation en environnement à risques, Class I, Division 2, Groups A, B, C et D.

Cette note fait référence à tous les produits Unitronics portant le symbole UL - produits qui ont été certifiés pour une utilisation dans des endroits dangereux, Classe I, Division 2, Groupes A, B, C et D.

- Attention*
- Cet équipement est adapté pour une utilisation en Classe I, Division 2, Groupes A, B, C et D, ou dans Non-dangereux endroits seulement.
 - Le câblage des entrées/sorties doit être en accord avec les méthodes de câblage selon la Classe I, Division 2 et en accord avec l'autorité compétente.
 - AVERTISSEMENT: Risque d'Explosion – Le remplacement de certains composants rend caduque la certification du produit selon la Classe I, Division 2.
 - AVERTISSEMENT - DANGER D'EXPLOSION - Ne connecter pas ou ne débranche pas l'équipement sans avoir préalablement coupé l'alimentation électrique ou la zone est reconnue pour être non dangereuse.
 - AVERTISSEMENT - L'exposition à certains produits chimiques peut dégrader les propriétés des matériaux utilisés pour l'étanchéité dans les relais.
 - Cet équipement doit être installé utilisant des méthodes de câblage suivant la norme Class I, Division 2 NEC et /ou CEC.

Certification de la résistance des sorties relais

Les produits énumérés ci-dessous contiennent des sorties relais:

- Modules d'Extensions d'E/S, modèles: IO-DI8-RO4, IO-DI8-RO4-L, IO-RO8, IO-RO8L.
- Lorsque ces produits spécifiques sont utilisés dans des endroits dangereux, ils supportent un courant de 3A charge résistive, lorsque ces produits spécifiques sont utilisés dans un environnement non dangereux, ils sont évalués à 5A res, comme indiqué dans les spécifications du produit Plages de températures.

The information in this document reflects products at the date of printing. Unitronics reserves the right, subject to all applicable laws, at any time, at its sole discretion, and without notice, to discontinue or change the features, designs, materials and other specifications of its products, and to either permanently or temporarily withdraw any of the forgoing from the market.

All information in this document is provided "as is" without warranty of any kind, either expressed or implied, including but not limited to any implied warranties of merchantability, fitness for a particular purpose, or non-infringement. Unitronics assumes no responsibility for errors or omissions in the information presented in this document. In no event shall Unitronics be liable for any special, incidental, indirect or consequential damages of any kind, or any damages whatsoever arising out of or in connection with the use or performance of this information.

The tradenames, trademarks, logos and service marks presented in this document, including their design, are the property of Unitronics (1989) (R"G) Ltd. or other third parties and you are not permitted to use them without the prior written consent of Unitronics or such third party as may own them.