

# I/O Expansion Module

## 8 Inputs, 8 Outputs

## User Guide EX90-DI8-RO8

The EX90-DI8-RO8 is an I/O expansion module that can be used in conjunction with specific Unitronics OPLC controllers. The module offers 8 digital inputs, type pnp (source), and 8 relay outputs.

The EX90-DI8-RO8 is snap-mounted on a DIN rail.

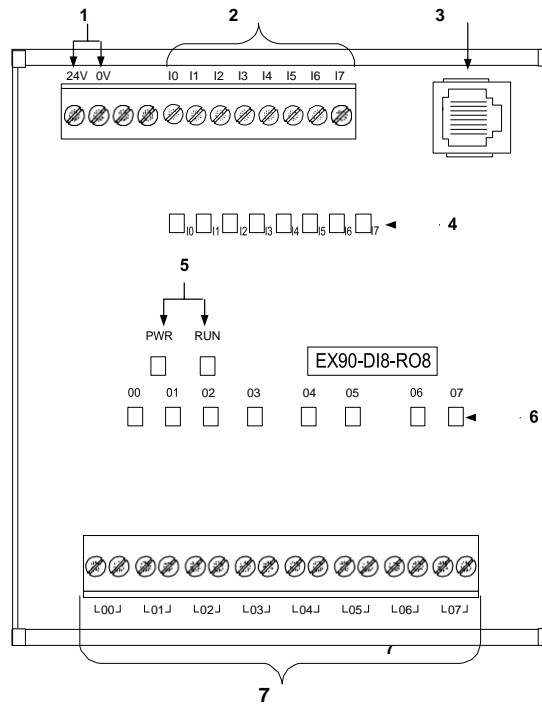

### Component identification

1	Power supply
2	Input connection points
3	OPLC-module communication port
4	Input status indicators
5	Status indicators
6	Output status indicators
7	Output connection points

- Before using this product, it is the responsibility of the user to read and understand this document and any accompanying documentation.
- All examples and diagrams shown herein are intended to aid understanding, and do not guarantee operation. Unitronics accepts no responsibility for actual use of this product based on these examples.
- Please dispose of this product in accordance with local and national standards and regulations.
- Only qualified service personnel should open this device or carry out repairs.

### User safety and equipment protection guidelines

This document is intended to aid trained and competent personnel in the installation of this equipment as defined by the European directives for machinery, low voltage, and EMC. Only a technician or engineer trained in the local and national electrical standards should perform tasks associated with the device's electrical wiring.

Symbols are used to highlight information relating to the user's personal safety and equipment protection throughout this document. When these symbols appear, the associated information must be read carefully and understood fully.

Symbol	Meaning	Description
	Danger	The identified danger causes physical and property damage.
	Warning	The identified danger can cause physical and property damage.
<i>Caution</i>	Caution	Use caution.



- Failure to comply with appropriate safety guidelines can result in severe personal injury or property damage. Always exercise proper caution when working with electrical equipment.



- Check the user program before running it.
- Do not attempt to use this device with parameters that exceed permissible levels.
- Install an external circuit breaker and take appropriate safety measures against short-circuiting in external wiring.
- To avoid damaging the system, do not connect / disconnect the device when the power is on.

**Environmental Considerations**



- Do not install in areas with: excessive or conductive dust, corrosive or flammable gas, moisture or rain, excessive heat, regular impact shocks or excessive vibration.



- Leave a minimum of 10mm space for ventilation between the top and bottom edges of the device and the enclosure walls.
- Do not place in water or let water leak onto the unit.
- Do not allow debris to fall inside the unit during installation.

**Mounting the Module**

**Mounting Considerations**

- Do not install in areas with: excessive or conductive dust, corrosive or flammable gas, moisture or rain, excessive heat, regular impact shocks or excessive vibration.
- Provide proper ventilation by leaving a minimum space of 10mm between the top and bottom edges of the device and the enclosure walls.
- Do not place in water or let water leak onto the unit.
- Do not allow debris to fall inside the unit during installation.

**DIN-rail mounting**

- 1 Snap the EX90-DI8-RO8 onto the DIN rail as shown below; the device will be squarely situated on the DIN rail as shown below.

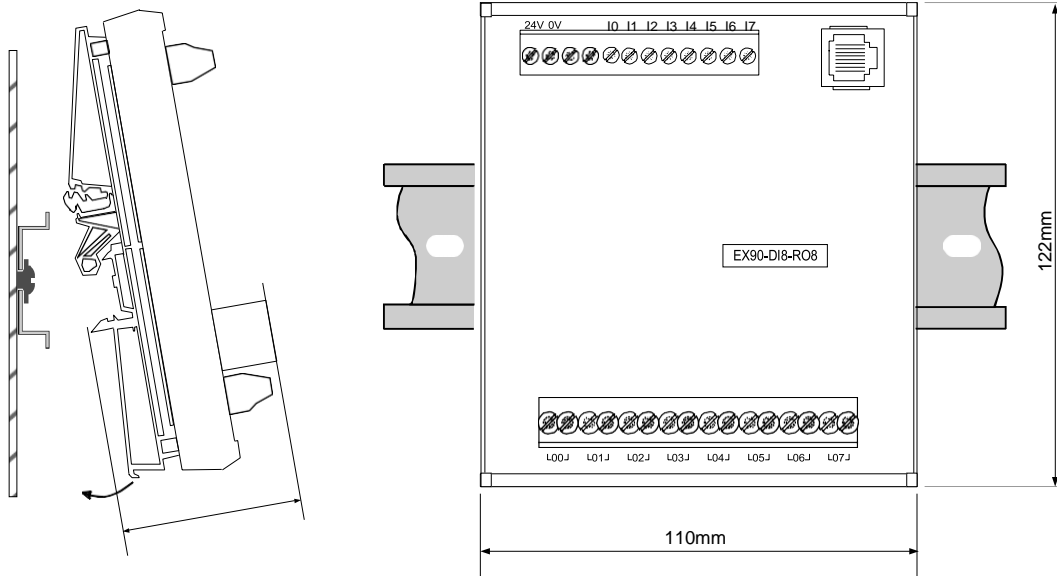

**Connecting the OPLC to the EX90-DI8-RO8**

An OPLC, such as the M90 micro-OPLC, is connected to the EX90-DI8-RO8 as shown below, via a category 5 shielded twisted pair cable (CAT 5, STP), terminated by RJ45 connectors. The cable provided with the EX90-DI8-RO8 is one meter long; cables of other lengths are available by separate order.

Note that the cable must be earthed on the M90 side, via the yellow-green wire.

To avoid damaging the system, do not connect or disconnect the device when the power is on.

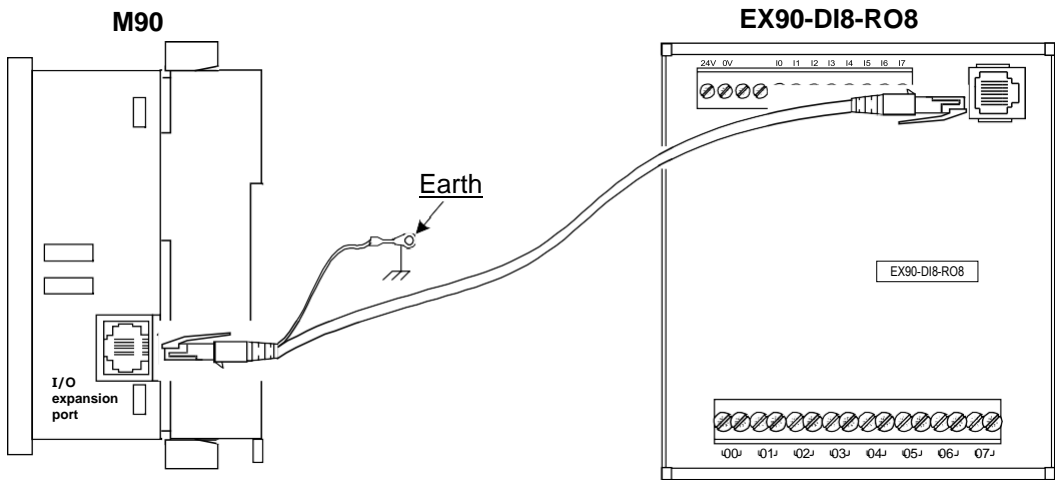

Shielded RJ45 connector pin-out

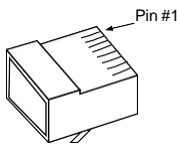

RJ-45 pin #	signal
1	D -
8	D +
2	CK-
4	CK+
3	0V
6	0V

Cable description

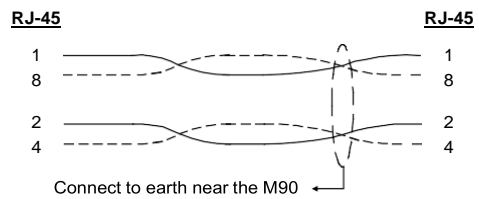

## Wiring

### Wire Size

Use 26-12 AWG wire (0.13 mm<sup>2</sup>–3.31 mm<sup>2</sup>) for all wiring purposes.

### Wiring Considerations

- Do not use tin, solder or any other substance on the stripped wire that might cause the wire strand to break.
- We recommend that you use crimp terminals for wiring.
- Install at maximum distance from high-voltage cables and power equipment.

### General Wiring Procedures

- 1 Strip the wire to a length of 7±0.5mm (0.250–0.300 inches).
- 2 Unscrew the terminal to its widest position before inserting a wire.
- 3 Insert the wire completely into the terminal to ensure that a proper connection can be made.
- 4 Tighten enough to keep the wire from pulling free.

To avoid damaging the wire, do not exceed a maximum torque of 0.5 N·m (5 kgf·m).



- Do not touch live wires.
- Double-check all the wiring before turning on the power supply.

• **Wiring**

Wiring DC Power Supply

- 1 Connect the "positive" cable to the 24V terminal, and the "negative" to the 0V terminal.
  - A non-isolated power supply can be used provided that a 0V signal is connected to the chassis.
  - Do not connect the 'Neutral' or 'Line' signal of the 110/220VAC to the device's 0V pin.
  - In the event of voltage fluctuations or non-conformity to voltage power supply specifications, connect the device to a regulated power supply.

Wiring I/Os

- Input or output cables should not be run through the same multi-core cable or share the same wire.
- Allow for voltage drop and noise interference with input/output lines used over an extended distance. Use wire that is properly sized for the load.

Wiring Inputs

- Note that the power supply and input signals must be connected to the same 0V signal.

*pnp (source) inputs*

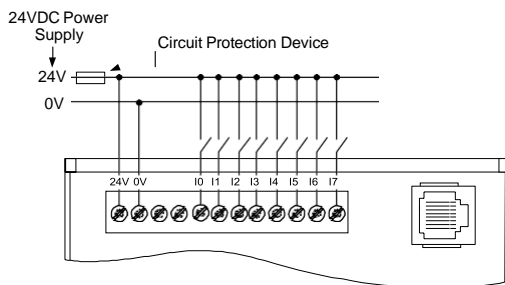

*pnp (source)*

*high-speed counter/frequency measurer*

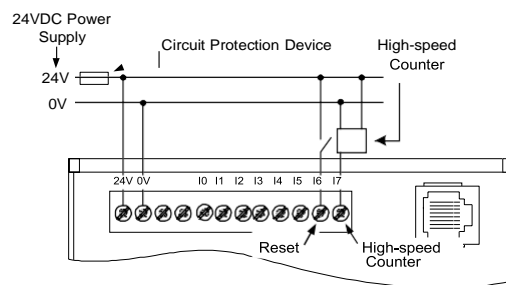

Wiring Outputs

The EX90-DI8-RO8 has 8 relay outputs. To increase the life span of these contacts and protect the EX90-DI8-RO8 from potential damage by reverse EMF, connect:

- a clamping diode in parallel with each inductive DC load,
- an RC snubber circuit in parallel with each inductive AC load.

*Outputs*

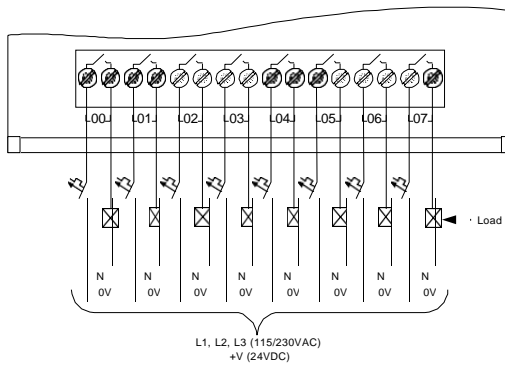

*Increasing Contact Life Span*

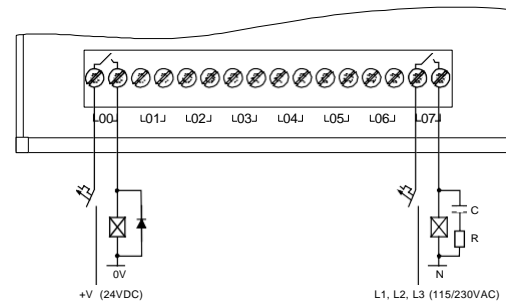

## EX90-DI8-RO8 Technical Specifications

<b>Power Supply</b>	See Note 1.
Input voltage	24VDC
Permissible range	20.4 to 28.8VDC
Max. current consumption	150mA@ 24VDC
Typical power consumption	2.5W@ 24VDC
Status indicators	
(RUN)	Green LED: —Lit when a communication link is established between module and OPLC. —Blinks when the communication link fails.
(PWR)	Green LED: Lit when power is on.

<b>Inputs</b>	
Number of inputs	8 (in one group)
Input type	pnP (source)
Galvanic isolation	None
Status indicators (I0 to I7)	Green LEDs—Lit when the corresponding input is active.
Nominal input voltage	24VDC
Input voltage	0-5VDC for Logic '0' 15-28.8VDC for Logic '1'
Input current	7.5mA@ 24VDC
Response time	10mSec
Input #7	The specifications below apply when this input is wired for use as a high-speed counter input/frequency measurer. See Notes 2 and 3.
Resolution	16-bit
Frequency	5kHz maximum
Minimum pulse width	80µs

<b>Outputs</b>	
Number of outputs	8 relay
Output type	SPST-NO relay; 230VAC / 24VDC
Type of relay	Takamisawa JY-24H-K or NAIS (Matsushita) JQ1AP-24V or OMRON G6B-1114P-24VDC
Isolation	By relay
Output current	5A maximum (resistive load) 1A maximum (inductive load)
Maximum frequency	10Hz
Contact protection	External precautions required (see page 4, Increasing Contact Life Span)
Status Indicators	
(O0 to O7)	Red LEDs—Lit when the corresponding output is active.

<b>Environmental</b>	
Operating temperature	0° to 50° C
Storage temperature	-20° to 60° C
Dimensions (WxHxD)	110mm x 122mm x 55mm
Weight	212g (7.42oz.)
Mounting	Snaps onto a 35mm DIN-rail

### Notes:

1. Note that both the OPLC and the EX90-DI8-RO8 must be connected to the same power supply. The EX90-DI8-RO8 and the OPLC must be turned on and off simultaneously.
2. Input #7 can function either as a high-speed counter, a frequency measurer, or as a normal digital input. When Input #7 is used as a normal digital input, normal input specifications apply.
3. Input #6 can function either as the counter's reset, or as a normal digital input; in either case, its specifications are those of a normal digital input.

## Accessories

EX1-CA050	0.5 meter communication cable
EX1-CA100*	1 meter communication cable
EX1-CA200	2 meter communication cable
EX1-CA400	4 meter communication cable

\*EX1-CA100 is provided with the EX90-DI8-RO8; other cables are available by separate order.

## Addressing I/Os on M90 Expansion Modules

Inputs and outputs located on I/O expansion modules that are connected into an M90 OPLC are assigned addresses that comprise a letter and a number. The letter indicates whether the I/O is an input (I) or an output (O). The number indicates the I/O's location in the system. This number relates to both the position of the expansion module in the system, and to the position of the I/O on that module. Expansion modules are numbered from 0-7 as shown in the figure below.



The formula below is used to assign addresses for I/O modules used in conjunction with the M90 OPLC.

X is the number representing a specific module's location (0-7). Y is the number of the input or output on that specific module (0-15).

The number that represents the I/O's location is equal to:

$$32 + x \cdot 16 + y$$

### Examples

- Input #3, located on expansion module #2 in the system, will be addressed as I 67,  $67 = 32 + 2 \cdot 16 + 3$
- Output #4, located on expansion module #3 in the system, will be addressed as O 84,  $84 = 32 + 3 \cdot 16 + 4$ .

EX90-DI8-RO8 is a stand-alone I/O module. Even if it is the only module in the configuration, the EX90-DI8-RO8 is always assigned the number 7.

Its I/Os are addressed accordingly.

### Example

- Input #5, located on an EX90-DI8-RO8 connected to an M90 OPLC will be addressed as I 149,  $149 = 32 + 7 \cdot 16 + 5$

The information in this document reflects products at the date of printing. Unitronics reserves the right, subject to all applicable laws, at any time, at its sole discretion, and without notice, to discontinue or change the features, designs, materials and other specifications of its products, and to either permanently or temporarily withdraw any of the foregoing from the market.

All information in this document is provided "as is" without warranty of any kind, either expressed or implied, including but not limited to any implied warranties of merchantability, fitness for a particular purpose, or non-infringement. Unitronics assumes no responsibility for errors or omissions in the information presented in this document. In no event shall Unitronics be liable for any special, incidental, indirect or consequential damages of any kind, or any damages whatsoever arising out of or in connection with the use or performance of this information.

The tradenames, trademarks, logos and service marks presented in this document, including their design, are the property of Unitronics (1989) (R"G) Ltd. or other third parties and you are not permitted to use them without the prior written consent of Unitronics or such third party as may own them