

Technical Specifications

UniStream® HMI Panel

**USP-070-B08, USP-070-C08, USP-070-B10,
USP-070-C10, USP-104-B10, USP-104-C10,
USP-104-M10, USP-156-B10, USP-156-C10**

UniStream® HMI Panels provide the foundation of an all-in-one PLC + HMI controller. To create an all-in-one device, snap a UniStream® CPU-for-Panel and one or more Uni-I/O™ or Uni-COM™ modules onto the back of the panel.

UniStream connects directly to UniCloud, Unitronics' IIoT cloud platform using built-in UniCloud connectivity. Model number ending with **Cxx** provided with built-in 5 years UniCloud start-up subscription with no additional payment required for this period. More information about UniCloud is available at www.unitronics.cloud.

Installation Guides are available in the Unitronics Technical Library at www.unitronicsplc.com.

Power Supply	USP-070-x08	USP-070-x10	USP-104-x10	USP-104-x10	USP-156-x10
Input voltage	12VDC or 24VDC				
Permissible range	10.2VDC to 28.8VDC				
Max. current consumption	1.35A@12VDC, 0.65A@24VDC	1.5A@12VDC, 0.75A@24VDC	1.62A@12VDC, 0.81A@24VDC		2.5A@12VDC, 1.25A@24VDC

Display	USP-070-x08	USP-070-x10	USP-104-x10	USP-104-M10	USP-156-x10
LCD type	TFT				
Backlight type	White LED				
Luminous intensity (brightness)	Typically 400 nits (cd/m ²), at 25°C				
Backlight longevity ⁽¹⁾	30k hours	50k hours			
Resolution (pixels)	800 x 480 (WVGA)	800 x 480 (WVGA)	800 x 600 (SVGA)		1366 x 768
Size	7"	7"	10.4"		15.6"
Viewing area Height x Width (mm)	154.08 x 85.92	152.4 x 91.44	211.2 x 158.4		344.23 x 193.53
Color support	65,536 (16bit)				16M (24bit)
Surface treatment	Anti-glare				
Touch screen	Resistive Analog			Capacitive multi-touch, 5-fingers	Resistive Analog
Actuation force (min)	> 80 g (0.176 lb)				

System	
Processor	32 bit, 800MHz RISC Processor, with Graphic Accelerator
Internal memory	RAM: 512 MB ROM: 3GB system memory 1GB user memory
External memory	microSD or microSDHC card Size: up to 32GB, Data Speed: up to 200Mbps

Audio ⁽²⁾	
Bit Rate	192kbps
Internal speaker	Audio compatibility: mono MP3 files. Frequency range: 500Hz to 20KHz
External audio	Audio compatibility: stereo MP3 files. Interface: 3.5mm Audio-out jack - use shielded audio cable of up to 3 m (9.84 ft). Impedance: 32Ω No isolation

Video	
Support Formats	MPEG-4 Visual , AVC/H.264

Communication	
Ethernet port	
Number of ports	2
Port type	10/100 Base-T (RJ45)
Auto crossover	Yes
Auto negotiation	Yes
Isolation voltage	500VAC for 1 minute
Cable	Shielded CAT5e cable, up to 100 m (328 ft)
USB device ⁽³⁾	
Number of ports	1
Port type	Mini-B
Data rate	USB 2.0 (480Mbps)
Isolation	None
Cable	USB 2.0 compliant; < 3 m (9.84 ft)
USB host	
Number of ports	2
Port type	Type A
Data rate	USB 2.0 (480Mbps)

Isolation	None
Cable	USB 2.0 compliant; < 3 m (9.84 ft)
Over current protection	Yes

On-board I/O or COM modules ⁽⁴⁾	USP-070-x08, USP-070-x10	USP-104-x10, USP-104-M10 USP-156-x10
Number of modules	Up to 3	Up to 5 (up to 4 of them can be COM modules)

Note that the numbers above relate to Uni-I/O and Uni-COM modules. You can mix Uni-I/O and Uni-COM modules with Uni-I/O Wide modules, considering that 1 Uni-I/O Wide module equals 1½ Uni-I/O module. For example, the USP-104-x10 and USP-104-M10 back panel can host 2 Uni-I/O and 2 Uni-I/O Wide modules in any order.

Environmental		
Protection	Front face ⁽²⁾ : IP65/IP66, NEMA 4X Rear side: IP20, NEMA1	
	USP-070-x08, USP-070-x10, USP-104-x10, USP-104-M10	USP-156-x10
Operating temperature	-20°C to 55°C (-4°F to 131°F)	0°C to 50°C (32°F to 122°F)
Storage temperature	-30°C to 70°C (-22°F to 158°F)	-20°C to 60°C (-4°F to 140°F)
Relative Humidity (RH)	5% to 95% (non-condensing)	
Operating Altitude	2,000 m (6,562 ft)	
Shock	IEC 60068-2-27, 15G, 11ms duration	
Vibration	IEC 60068-2-6, 5Hz to 8.4Hz, 3.5mm constant amplitude, 8.4Hz to 150Hz, 1G acceleration	

Dimensions	USP-070-x08	USP-070-x10	USP-104-x10	USP-104-M10	USP-156-x10
Weight	0.7 Kg (1.54 lb)	0.7 Kg (1.54 lb)	1.45 Kg (3.20 lb)	1.45 Kg (3.20 lb)	3 Kg (3.60 lb)
Size	Refer to the images below				

USP-070-x08 , USP-070-x10 7" Panel

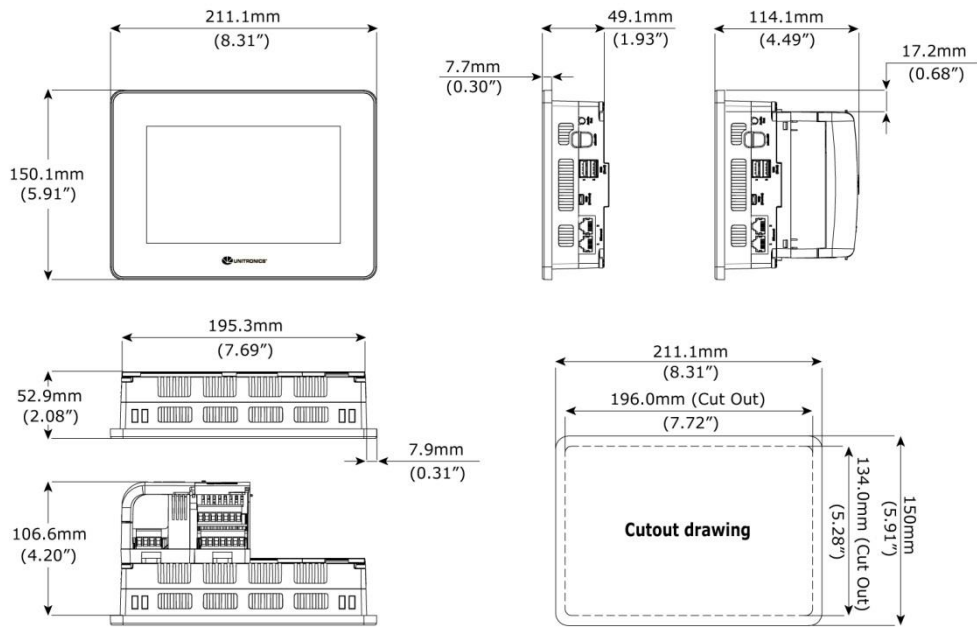

USP-104-x10, USP-104-M10 10.4" Panel

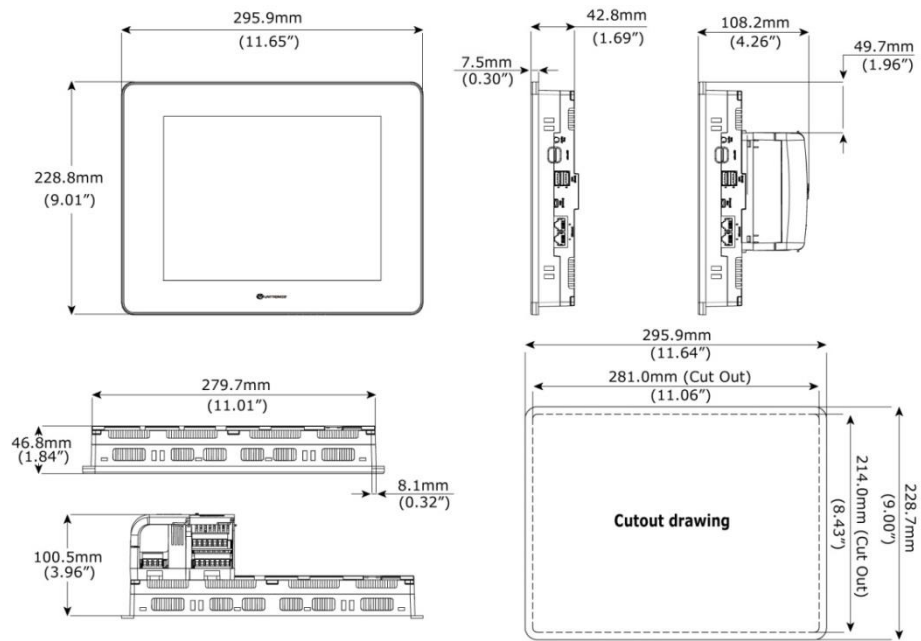

USP-156-x10 15.6" Panel

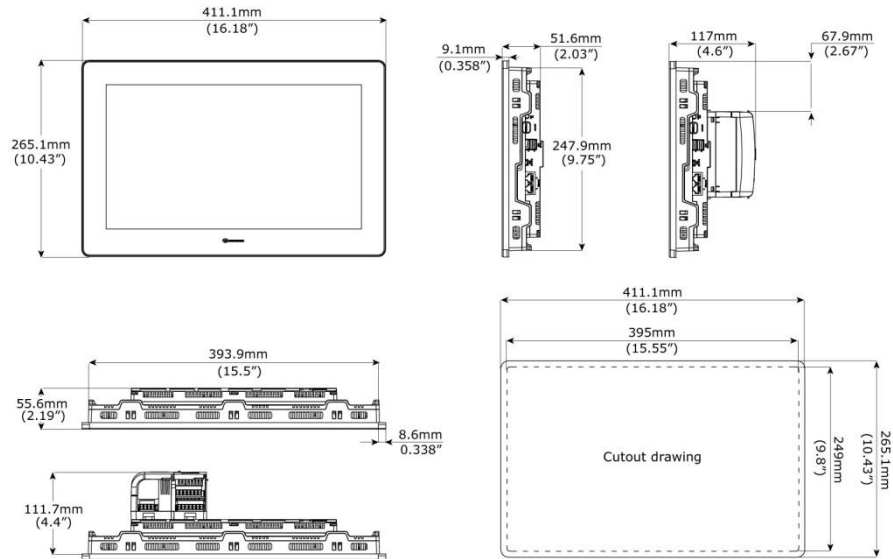
**Notes:**

1. Panel's longevity is the typical operating time after which the brightness drops to 50% of its original level.
2. The audio outlet seal must be inserted in the outlet in order to comply with IP66 or NEMA 4X.
3. The USB device port is used to connect the device to a PC.
4. The panel back is molded into a DIN rail-like structure which provides the physical support for a UniStream® CPU-for-Panel, Uni-I/O™ modules and Uni-Com™ modules. Details are provided in the UniStream® HMI Panel installation guides.

The information in this document reflects products at the date of printing. Unitronics reserves the right, subject to all applicable laws, at any time, at its sole discretion, and without notice, to discontinue or change the features, designs, materials and other specifications of its products, and to either permanently or temporarily withdraw any of the forgoing from the market.

All information in this document is provided "as is" without warranty of any kind, either expressed or implied, including but not limited to any implied warranties of merchantability, fitness for a particular purpose, or non-infringement. Unitronics assumes no responsibility for errors or omissions in the information presented in this document. In no event shall Unitronics be liable for any special, incidental, indirect or consequential damages of any kind, or any damages whatsoever arising out of or in connection with the use or performance of this information.

The tradenames, trademarks, logos and service marks presented in this document, including their design, are the property of Unitronics (1989) (R"G) Ltd. or other third parties and you are not permitted to use them without the prior written consent of Unitronics or such third party as may own them.

DOC21003-A8 REV. A03 12/20